

ELECTRONIC CONDENSATE DRAIN - IED

DESCRIPTION

IED drain series has been developed for fully automatic discharging of condensate or any other non-aggressive fluid from compressed air⁽¹⁾ system. The series is designed to discharge condensed water from filter housing primarily. Condensate accumulates in the bottom of filter housing. Fluid level is detected by precise capacitive level sensor. When the level is high enough condensate is being discharged from the system without any air losses.

IED drain series is also equipped with led indicator and test button.

APPLICATIONS⁽²⁾

- Air filter

⁽¹⁾ For any other technical gas please contact us or your local dealer

⁽²⁾ IED series can be used in other applications. But, for applications not listed please contact us or your local dealer.



TECHNICAL SPECIFICATION

Type	IED 230V	IED C 230V	IED 115V	IED C 115V
Service Network Connection	No	Yes	No	Yes
Voltage	230VAC, 50 – 60 Hz		115VAC, 50 – 60 Hz	
Internal fuse	5X20 1A T		5X20 1A T	
Power	10VA		10VA	
Operating pressure range	0 – 16 bar(g) 0 – 232 psi			
Drain capacity (@ 7 bar, 101 psi)	8 l/h 0.005 cfm			
Operating temperature range	1,5°C – 65°C			
Protection class	54			
Inlet connection	G 1/2" (parallel thread)			
Outlet connection	Push connection for tube ø8			
Mass	0.3 kg			

Filter capacities by region	Northern Europe, Canada, Central Asia	Rest of the world	Moist tropical and subtropical regions
Peak filter capacity [m ³ /min]	70	55	34

The amount of condensed water in compressed air system depends mainly on outside air temperature

TYPES

Type IED C provides Service Network connector which comprises an alarm signal.

Connector pins' description (IED-C side):

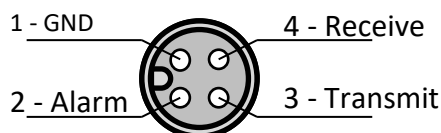

Standard M12 sensor/actuator connector 4 pin, plug

Alarm Output Circuit:

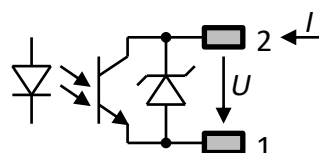

U_{max} (at high impedance): 39V
 I_{max} (at low impedance): 200mA
 U reverse: -0,7V

Service Network and alarm signals are voltage free

MATERIALS

Part	Material
Housing	PA 6
Valve	Stainless steel 1.4057, Brass
Level sensor	PP (polypropylene)
Sealing	NBR

DIMENSIONS

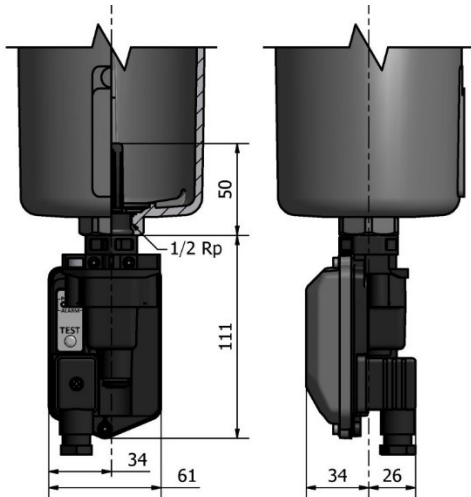

PRESSURE EQUIPMENT DIRECTIVE PED 2014/68/EU (Fluid group 2)

Product	Category, module
IED	Not required

MAINTENANCE

At filter cartridge replacement check also the drain and make sure there is no visual damage or leakage. Check LED indicator and press the test button to check operation of the drain regularly.

Condensate discharged from compressed air system contains significant amounts of lubricant oil. We strongly recommend connecting IED to oil water separator. In most countries content of oil in waste water is regulated by law.

INFORMATION IN THIS DOCUMENT IS SUBJECT TO CHANGE WITHOUT NOTICE

	<p>Our quality management system is certified by BUREAU VERITAS in conformity with ISO 9001:2015 Reg. number: 200285</p>	
---	--	--